

SA FILLERS (PTY) LTD

REG NO 2015/396381/07

VAT NO 4100278086

8 HEAD LIFTING TABLE GRAVITY FILLER WITH CENTER CONVEYOR:

Machine Specifications:

Model	- Pneumatic lifting table
Products to fill.	- Water, juice and milk
Bottle sizes	- 250ml up to 5L
Production speed	- 400 – 1 200 bottles per hour (Depending on operator)
Additional parts to add	- Extra filling valves, conveyor with packing table
Need compressed air	- 6 Bar 350l/min
Need power	- 220V single phase 5 Amp (if order the conveyor)
Machine size	- 1 500L x 900W x 1 950H (80kg)

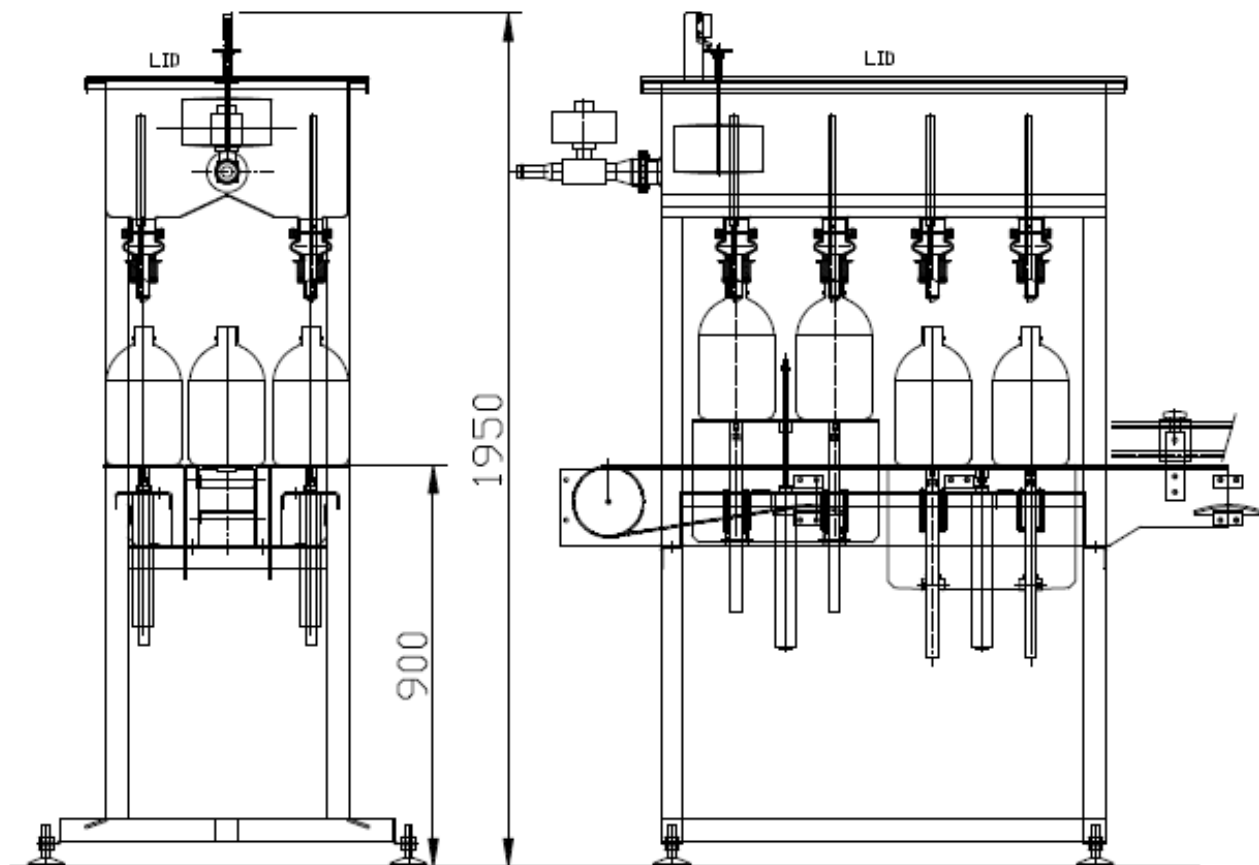

Address: 5 Goucom Road (Plot 2014)

Betty's Bay

Western Cape

7141

Contacts: J. Groenewald – 073 390 3814

